

Twin Hydradisc III[®] Double Disc Refiner

Homogeneous fibrillation
of pulp fibers for enhanced
product properties

*Optimized low
consistency design*

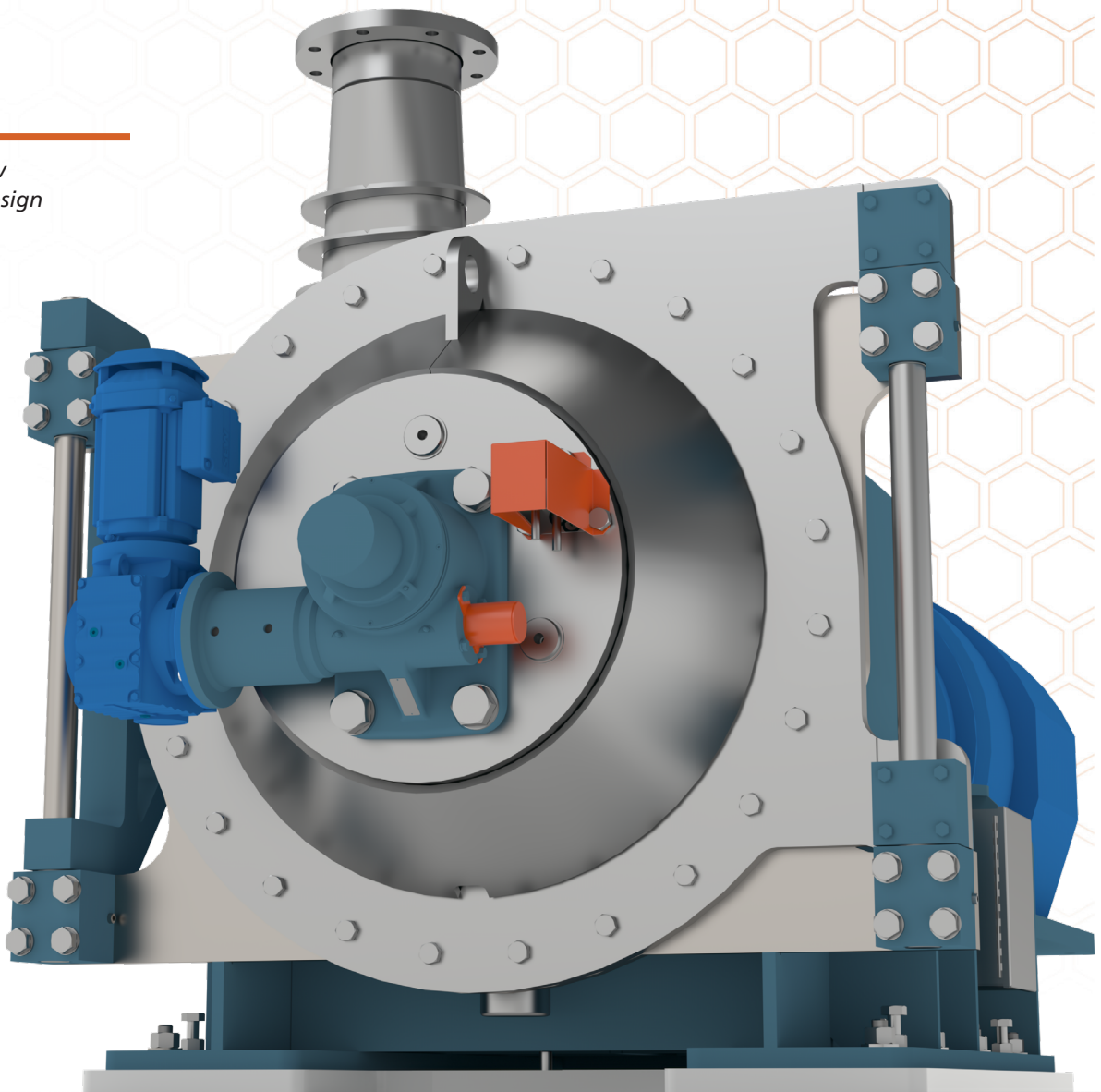

Twin Hydradisc III

Double Disc Refiner

Backed by over 2,000 refiner installations worldwide, and more than a century of pulp and paper industry experience, Kadant Twin Hydradisc refiners deliver the proven performance and precise control demanded by today's ever-challenging production requirements.

Refined for Performance

Our CFD-optimized Inlet feed and discharge design delivers maximized flow and capacity—equalizing the stock flow to each set of refining plates and ensuring optimum fiber refinement. This high-capacity design provides an optimal positive pressure change from inlet to discharge.

Refined for Sustainability

The unit features easy-access, powered plate adjustment and user-friendly position indicators. The refiner's self-centering shaft and floating rotor provides a smooth and balanced operation.

The power load is precisely controlled by electromechanical adjustment of the movable head. Net specific energy and advanced controls keep you running safe and efficient.



Yield-increasing efficiency and cost-saving control

Benefits



Balanced Precision

- Self-centering, floating shaft and rotor
- Pressure-balanced inlet provides even stock flow to each set of refining plates
- Movable power-adjusting stator



Agile Performance

- Frequency-controlled motor
- Variable adjustment speeds
- Precise power and load control



Safety in Mind

- Quick-opening hinged housing
- High speed back-out
- Over pressurization protection



Rugged Construction

- Solid stainless steel rotor, stator, and main body casing
- Self-aligning bearings enable easy and accurate field alignment



Flexible Application

- Multiple plate patterns available to suit specific stock requirements



Quick-opening hinged housing with integrated plate crane provides safe and easy maintenance access

Variable speed head adjustment precisely controls power load

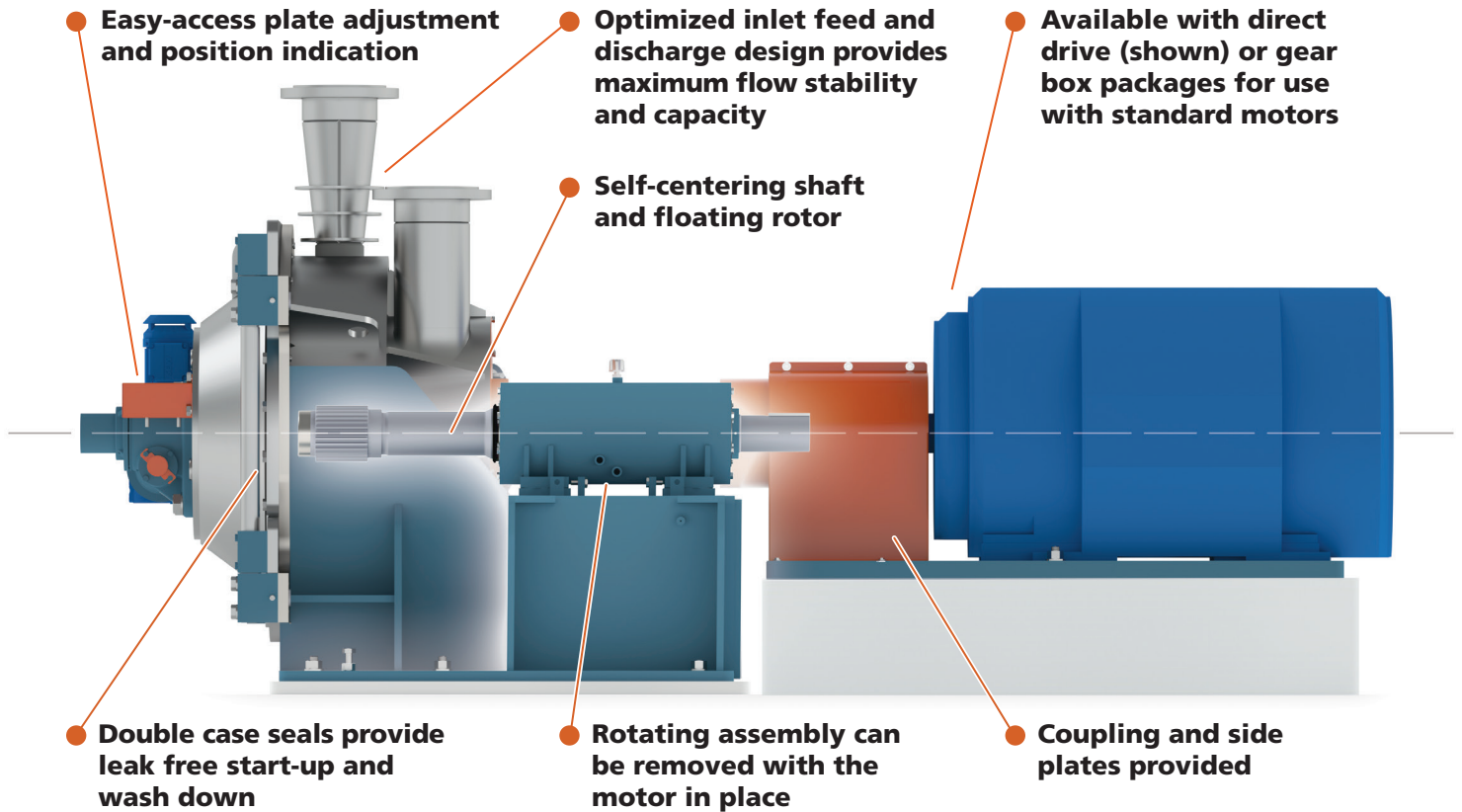

Optimized inlet design assures hydraulic stability and a uniform flow for maximum energy efficiency

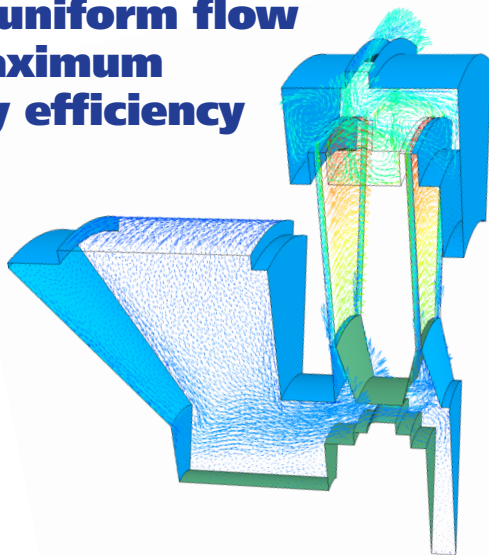

Seal water, safety set points and over pressurization protection



Easy field alignment of shaft and rotor

A Trusted Partner

Stock preparation is in our DNA. We know this industry like few others – your equipment, your processes, and your challenges. We have the know-how and tools to elevate the efficiency of your production. Our team can help monitor, maintain, and upgrade your line, providing process improvements, replacement parts, rebuilds, and comprehensive maintenance plans.

We understand what it takes to remain competitive, protect your investment, and extend the life of your stock preparation assets. To that goal, we offer:

- Field services, inspections, and audits
- Rebuilds and retrofits
- Upgrades and modernizations
- Maintenance and service contracts
- Process control solutions
- Replacement upgrades and spare parts

Certified Parts and Service 24 Hour Hotline for North America: 1-800-448-5422

Expertise to Empower You

Our team is there for you at every step. We help you select the right options to best meet your specific needs.

We have generations of experience, a history of innovation, and a proven record of success across the globe. Our skilled engineers, process professionals, application experts, manufacturing, and field service teams have thousands of successful installations to their credit.

Get You Running, Keep You Running

Our technical service and support teams are ready. We provide superior guidance in the planning, design, engineering, installation, and start-up of your systems. Our products and expertise cover the full range of stock preparation and pulping, including:

- Pulping
- Screening
- Cleaning
- Thickening
- Deinking
- Detrashing
- Refining and dispersing
- Reject handling
- Recovery systems
- Heat transfer
- Pulp washing
- Recausticizing

The Kadant Black Clawson **Foundations** product line offers a full range of fiber processing equipment and services.

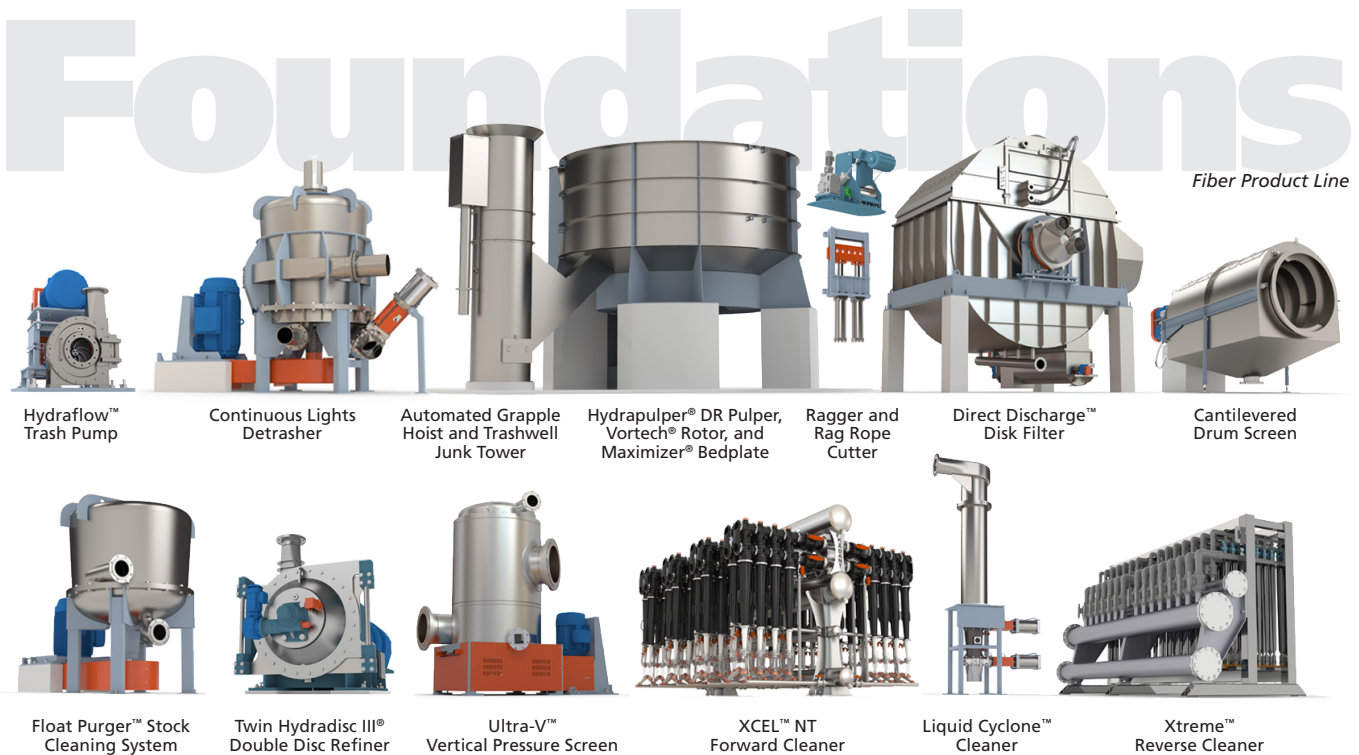

For patent information about this and other Kadant products visit <https://kadant.com/en/patents>

KADANT

fiberprocessing.kadant.com Kadant is a global supplier of high-value, critical components and engineered systems used in process industries worldwide.

North America, Central America, and Japan:

Kadant Black Clawson LLC
1425 Kingsview Drive
Lebanon, OH 45036 USA
Tel: +1-513-229-8100
Email: info@kadant.com

China, Taiwan, and South Korea:

Kadant Fiberline (China) Co. Ltd.
STE 1960, Beijing Sunflower Tower
37 Maizidian Street, Chaoyang
District, Beijing 100125 China
Phone: +86-10-65813011/12/13
Email: Marketing.KFC@kadant.com

EMEA, APAC, and South America:

Kadant Lamort SAS
39, rue de la Fontaine Ludot,
B. P. 30046
Vitry-le-Francois cedex 51302
Phone: +33-26-74-80-80
Email: kadant.lamort@kadant.com

Kadant Noss AB
Malmgatan 25
602 23 Norrkoping, Sweden
Phone: +46-(0)-11-23-15-00
Email: info.kadantnoss@kadant.com

Twin Hydradisic III Refiner
©2024 Kadant Inc
01/2024